

MXI-ARRANGEMENT-9, LEVEL 2, UPBLAST
 WITH CURB CAP AND/OR DISCHARGE CAP

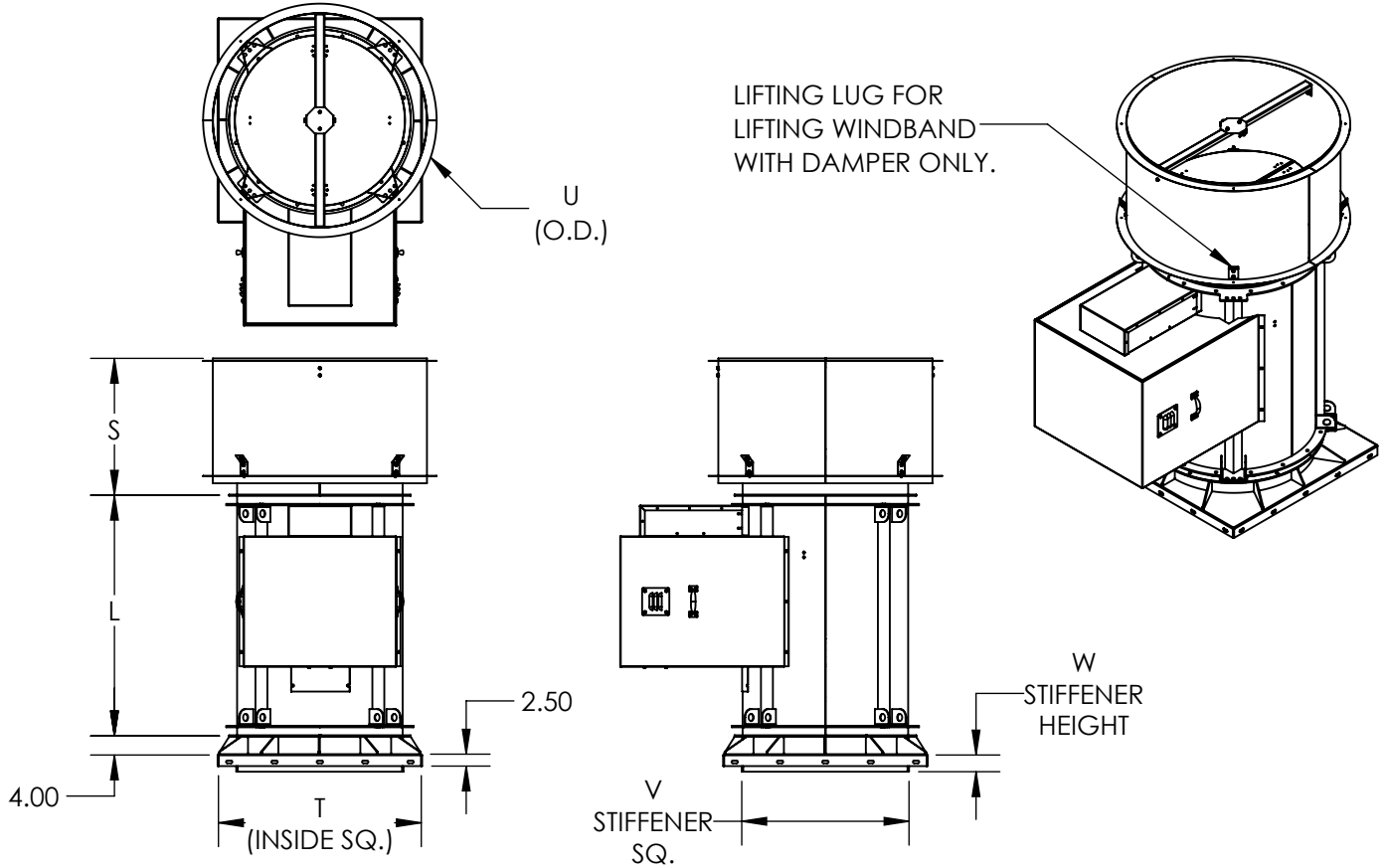

DIMENSIONAL DATA

SIZE	L	S	T	U	V	W	DISCH. CAP WEIGHT	CURB CAP WEIGHT	MXI-FAN WEIGHT (LESS MOTOR)	MXI-AF FAN WEIGHT (LESS MOTOR)
122	25 1/8	20 5/16	24 1/2	27 1/16	18 1/4	3 1/2	51	89	236	237
135	27 13/16	21 1/4	26 1/2	28 15/16	20 1/8	3 1/2	57	99	271	270
150	30 7/8	22 5/16	28 1/2	31 1/8	22 5/16	3 1/2	62	108	320	324
165	33 15/16	23 1/16	30 1/2	32 5/8	23 13/16	3 1/2	67	119	358	363
182	37 7/16	24 5/16	33 1/2	35 1/16	26 3/16	3 1/2	83	147	468	473
200	41 3/16	25 9/16	36 1/2	38 5/8	28 3/4	3 1/2	94	164	546	550
222	45 11/16	27 1/16	39 1/2	41 11/16	31 13/16	3 1/2	105	181	673	666
245	50 7/16	28 11/16	42 1/2	48 15/16	35 1/16	3 1/2	124	192	796	792
270	55 9/16	30 7/16	45 1/2	52 7/16	38 9/16	3 1/2	137	207	936	945
300	61 3/4	35 1/2	51 1/2	56 5/8	42 3/4	3 1/2	190	314	1154	1144
330	68	37 9/16	55 1/2	60 7/8	47	3 1/2	249	341	1343	1355
365	75 1/8	40	60 1/2	65 13/16	51 7/8	3 1/2	238	378	1878	1875
402	82 3/4	42 9/16	66 1/2	71	57 1/8	3 1/2	270	443	2260	2218
445	91 5/8	48 1/2	72 1/2	77	63 1/4	3 1/2	336	524	2732	2678
490	100 7/8	51 5/8	78 1/2	83 3/8	69 9/16	3 1/2	385	581	3175	-
542	111 9/16	55 1/4	87	90 11/16	76 7/8	3 1/2	491	690	3753	-
600	123 1/2	59 1/4	95	98 13/16	85 1/16	3 1/2	558	770	4480	-

ALL THE DIMENSIONS ARE INCHES AND WEIGHTS ARE IN LBS.

MXI-ARRANGEMENT-9, LEVEL 2, UPBLAST
 WITH CURB CAP AND/OR DISCHARGE CAP

WINDBAND ASSEMBLY

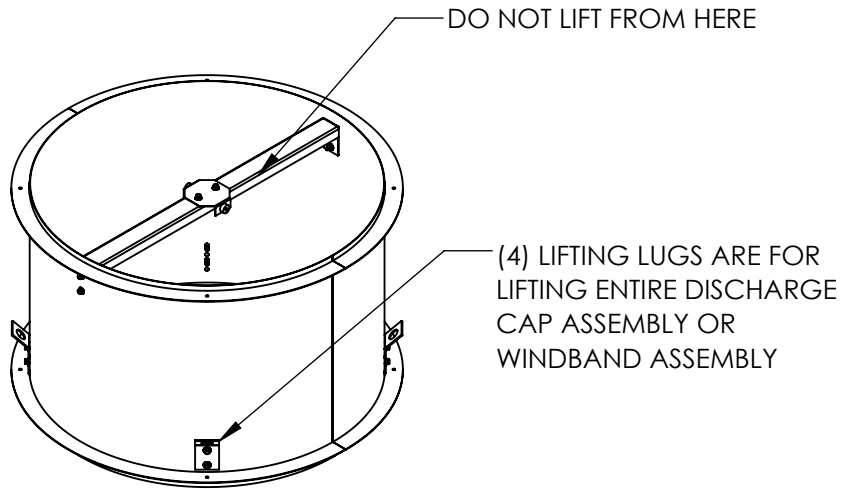

DAMPER ASSEMBLY

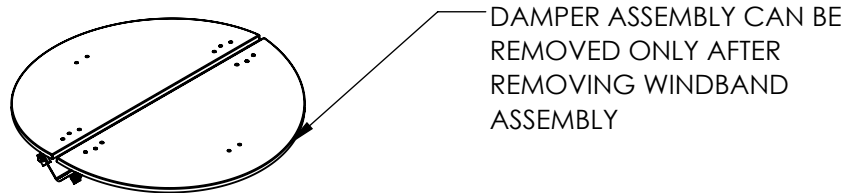

AIRSHAFT ASSEMBLY

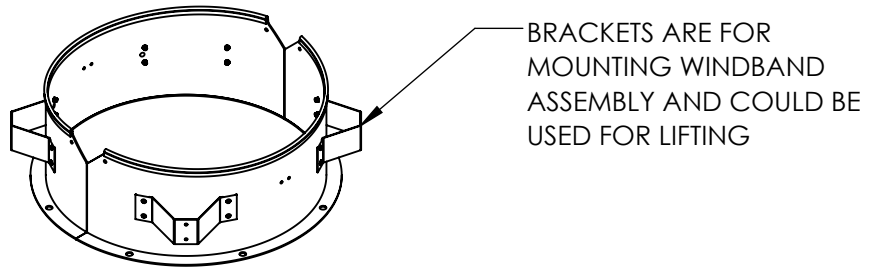

DISCHARGE CAP EXPLODED VIEW